

Remote Switch Kit

3 Sealed Momentary Pushbutton
Switches w/ 24 Inch Wire Leads

[SW-OEM-1](#)

DC-Digital
tm



Features

- Switch Kit provides remote operation of [DC-25-OEM](#)
- Black, soft dome is comfortable and aesthetic
- Wire leads are labeled for error free installation
- Separate common wires facilitate sign assembly
- 3 switches with all hardware included for easy installation
- Sealed pushbutton membrane is water resistant
- UL Listed, CSA Certified, and CE
- 24" long, 22 AWG wire leads
- 12 mm panel mounting hole, momentary, SPST

Options

- Custom wire lead Lengths
- Red and green buttons available (other colors may be available)
- Bulk quantities available
- Call for additional options
- [Industrial pushbutton](#)

Specifications

- **Standards** Conforming to UL508, CSA C22-2 No.14, IEC60529, NEMA ICS6-110
- **Approvals** CSA, UL, ROHS
- **Mechanical Life** 1,000,000
- **Protection** IP65; NEMA Type 1, 2, 3, 3R, 3S, 4, 5, 12, 13 (From front of Panel)
- **Weight** 1 Pound
- **Operating Temp** 0° to 49° Celsius (32° to 120° Fahrenheit)
- **Operating force** 3 Nm (306 grams)
- **Dimensions** .759 inch (1.93 cm) x .689 inch (1.75 cm) x .689 inch (1.75 inch) per switch

[SW-OEM-1](#) Description

The DC-Digital [SW-OEM-1](#) is designed to be used in a panel or enclosure where 3 momentary sealed pushbutton switches can provide remote operation of compatible DC-Digital displays. The soft dome is comfortable to the operator while the black metal housing blends in to any design. The pushbutton switches adapt the [DC-25-OEM](#) display to suit a large variety of applications, such as, industrial control panels, trade show fixtures, information exhibits, museums, arcade games, kiosks, automation, remote control and operator interfaces. It's proudly assembled in the USA by employees who value high quality and customer satisfaction.

SW-OEM-1 Mounting and Dimensions

Installation

1. Place the unit (less retaining nut) through the panel hole from front side of panel.
2. Install and tighten retaining nut. (15 in-lb)

Dimensions are in inches (mm)

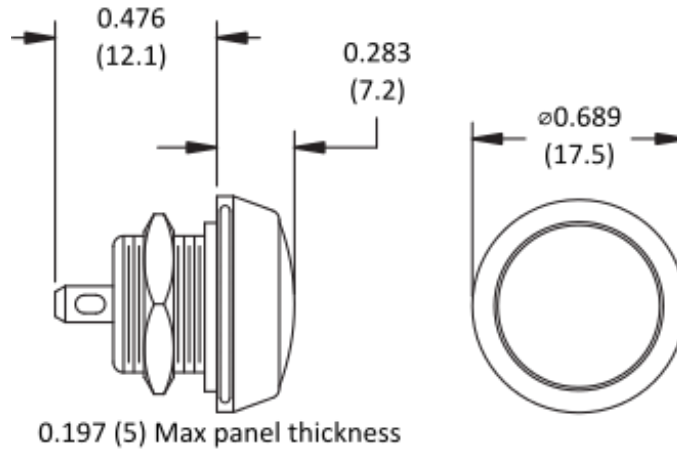

Panel Cut Out

